

DIMENSIONAL DRAWING OF THE BALL VALVE FIP TYPE VKD WITH MOUNTING KITS

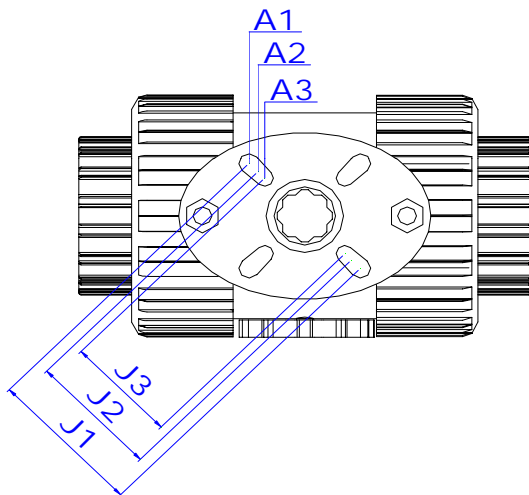

DN15, DN20 AND DN25 VALVE

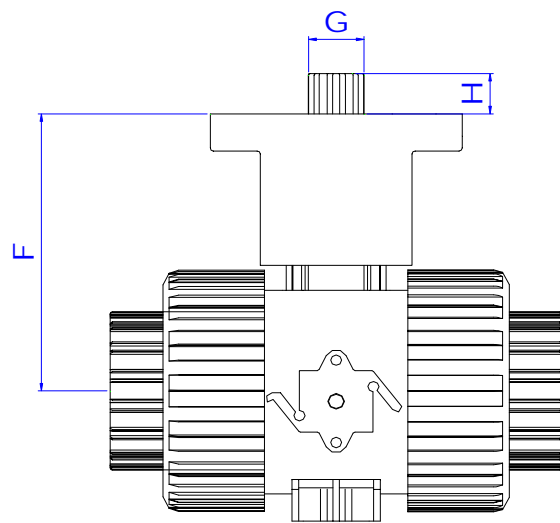
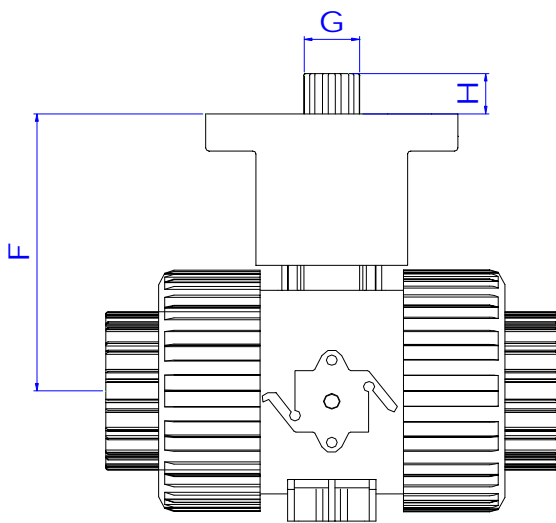
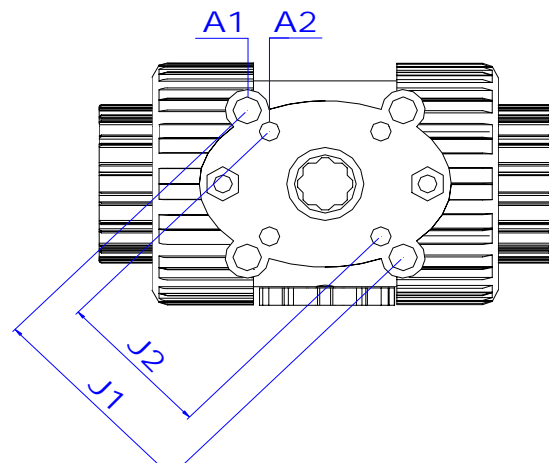

DN32, DN40 AND DN50 VALVE

d	DN	F	G	H	A1	A2	A3	J1	J2	J3
16-20	10-15	64	*9	9	∅ 6,1	∅ 5,1	∅ 5,1	50 (F05)	42 (F04)	36 (F03)
16-20	10-15	64	*11	11	∅ 6,1	∅ 5,1	∅ 5,1	50 (F05)	42 (F04)	36 (F03)
16-20	10-15	64	*14	15	∅ 6,1	∅ 5,1	∅ 5,1	50 (F05)	42 (F04)	36 (F03)
25	20	70	*11	11	∅ 6,1	∅ 5,1	∅ 5,1	50 (F05)	42 (F04)	36 (F03)
25	20	70	*14	15	∅ 6,1	∅ 5,1	∅ 5,1	50 (F05)	42 (F04)	36 (F03)
32	25	74	*11	11	∅ 6,1	∅ 5,1	∅ 5,1	50 (F05)	42 (F04)	36 (F03)
32	25	74	*14	15	∅ 6,1	∅ 5,1	∅ 5,1	50 (F05)	42 (F04)	36 (F03)
40	32	91	*11	11	∅ 9	∅ 6,5	-----	70 (F07)	50 (F05)	-----
40	32	91	*14	15	∅ 9	∅ 6,5	-----	70 (F07)	50 (F05)	-----
50	40	97	*14	15	∅ 9	∅ 6,5	-----	70 (F07)	50 (F05)	-----
50	40	97	*17	19	∅ 9	∅ 6,5	-----	70 (F07)	50 (F05)	-----
63	50	112	*14	15	∅ 9	∅ 6,5	-----	70 (F07)	50 (F05)	-----
63	50	112	*17	19	∅ 9	∅ 6,5	-----	70 (F07)	50 (F05)	-----

* Sizes in mm.

DEC-2011

PAG. 1

V001

DIMENSIONAL DRAWING OF THE BALL VALVE FIP TYPE VKD WITH MOUNTING KITS

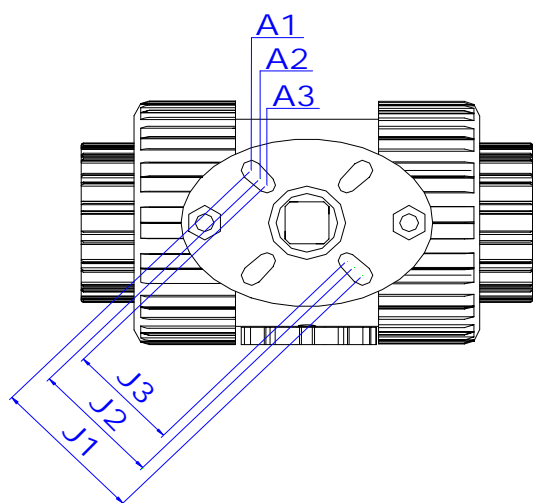
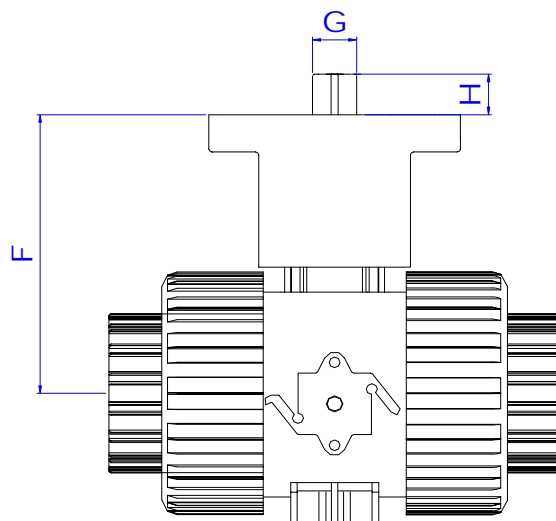
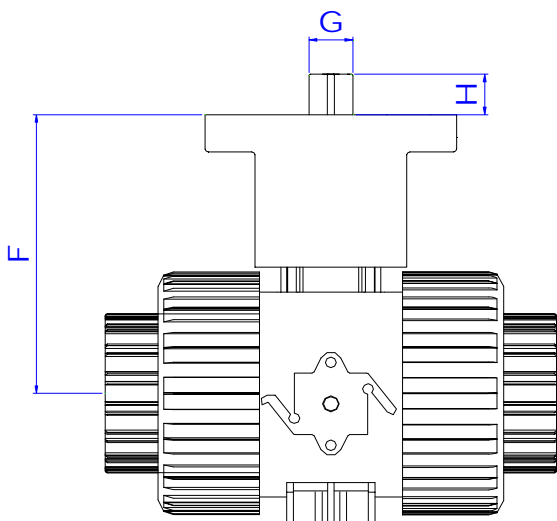

DN15, DN20 AND DN25 VALVE

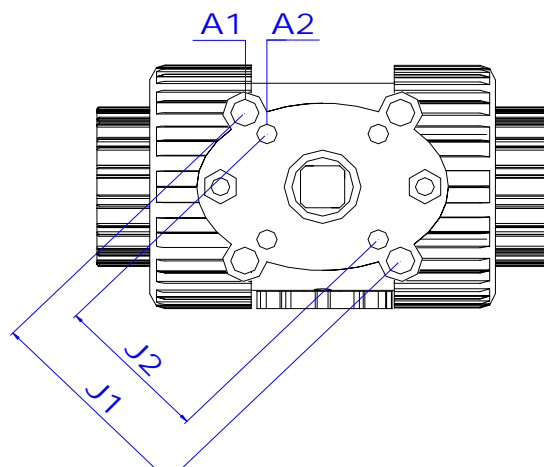

DN32, DN40 AND DN50 VALVE

d	DN	F	G	H	A1	A2	A3	J1	J2	J3
16-20	10-15	64	*9	9	∅ 6,1	∅ 5,1	∅ 5,1	50 (F05)	42 (F04)	36 (F03)
25	20	70	*9	9	∅ 6,1	∅ 5,1	∅ 5,1	50 (F05)	42 (F04)	36 (F03)
32	25	74	*9	9	∅ 6,1	∅ 5,1	∅ 5,1	50 (F05)	42 (F04)	36 (F03)
40	32	91	*11	11	∅ 9	∅ 6,5	-----	70 (F07)	50 (F05)	-----
50	40	97	*11	11	∅ 9	∅ 6,5	-----	70 (F07)	50 (F05)	-----
63	50	112	*11	11	∅ 9	∅ 6,5	-----	70 (F07)	50 (F05)	-----

* Sizes in mm.

DEC-2011

PAG. 2

V001