

INDEX - ÍNDICE

J4C - 140 (EN)

GENERAL CHARACTERISTICS 02
 SIZES 03
 EXPLODED VIEW 04

J4C - 140 (ES)

CARACTERÍSTICAS GENERALES 07
 MEDIDAS 08
 DESPIECE 09

J4C 140 - GENERAL CHARACTERISTICS



Technical Data	
Operation time unload	34 Sec. /90° (+/- 10%)
Maximum torque break	170 Nm / 1504,5 lb/in
Maximum operational torque	140 Nm / 1239 lb/in
Duty rating	75%
Max. Working angle	0° to 270°
Limit switch	4 SPST NO micro (2 motor stop and 2 confirmations)
Automatic heater	3,5 W
Grey Plug	EN 175301-803 FORM A
Black Plug	DIN43650/C
Protection IEC 60529 rating	IP67
Temperature	-20°C +70°C / -4°F +158°F
ISO 5211 Plate	Standard: F07/F10 Optional: F12
DIN 3337 Female output drive	Standard: *22 Optional: *17mm
Weight	4,72 kg

Electronic Data	
Electronic Torque Limiter function	
Electric motor	24VDC Brushless motor
Insulation	Class B
(IEC 60034) Service	S4

Voltage VDC/VAC 50/60Hz -0%+5%	
S140	24-240 VDC/VAC
B140	12 VDC/VAC ONLY

Options	
J4C 140/300 DPS KIT digital positioner	4-20mA, 0-20mA, 0-10V or 1-10V
J4C 140/300 BSR KIT emergency fail safe kit system by battery	NC - NO
Potentiometer	1K, 5K or 10K
3 position actuator	0°-45°-90° or 0°-90°-180°

Materials	Standard	Optional
Body	Anticorrosive Polyamide, Grey colour	Polypropilene V0, Black colour
Cover	Anticorrosive Polyamide, Red colour	Polypropilene V0, Natural colour
Output drive	Zamak, Zinc plated	Zamak, TEFLON coated
Flange	Aluminum and Cataphoresis	Aluminum and TEFLON coated
Main external shaft	Stainless Steel	-
External screws	Stainless Steel	-
Gears	Steel and Polyamide	-
Visual position indicator	Polyamide	-
Dome	Polycarbonate	-
Adjustable internal cams	Polyamide	-

Note: Technical data are the same despite the different casings.

J4C 140 - SIZES

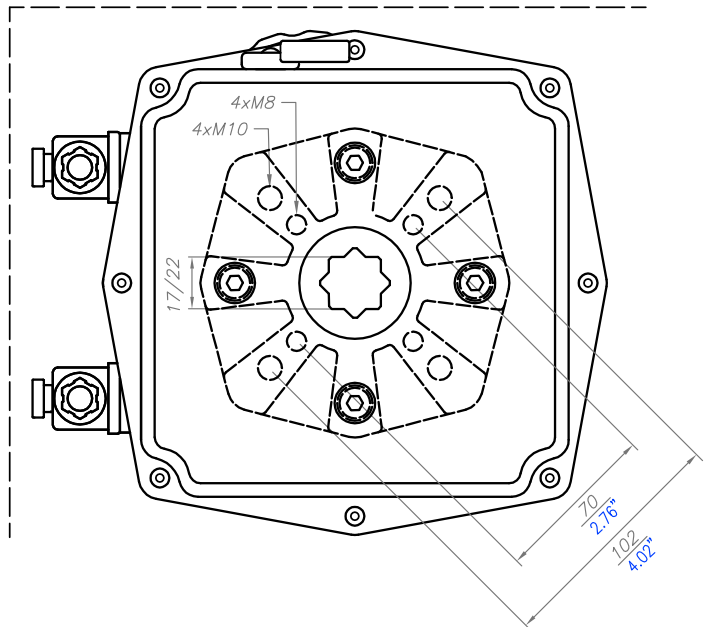
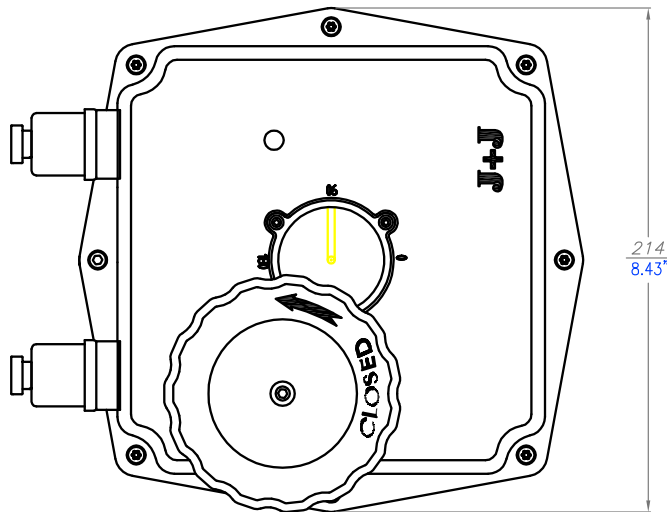
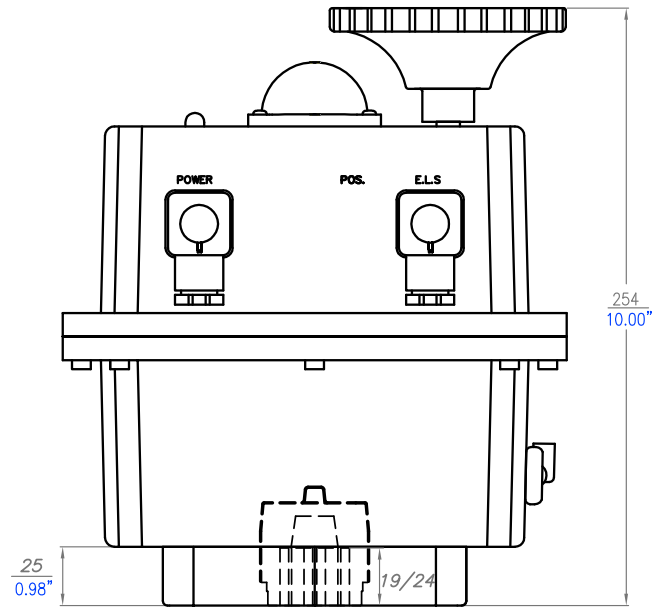
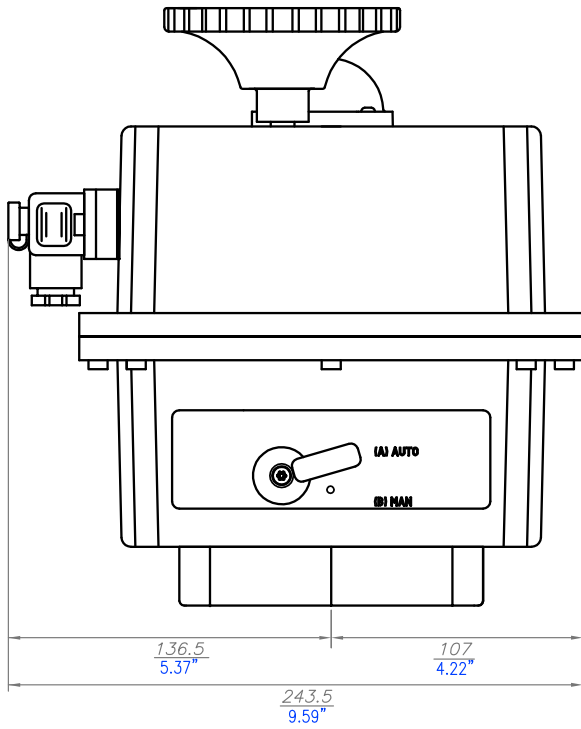

EXPLODED VIEW

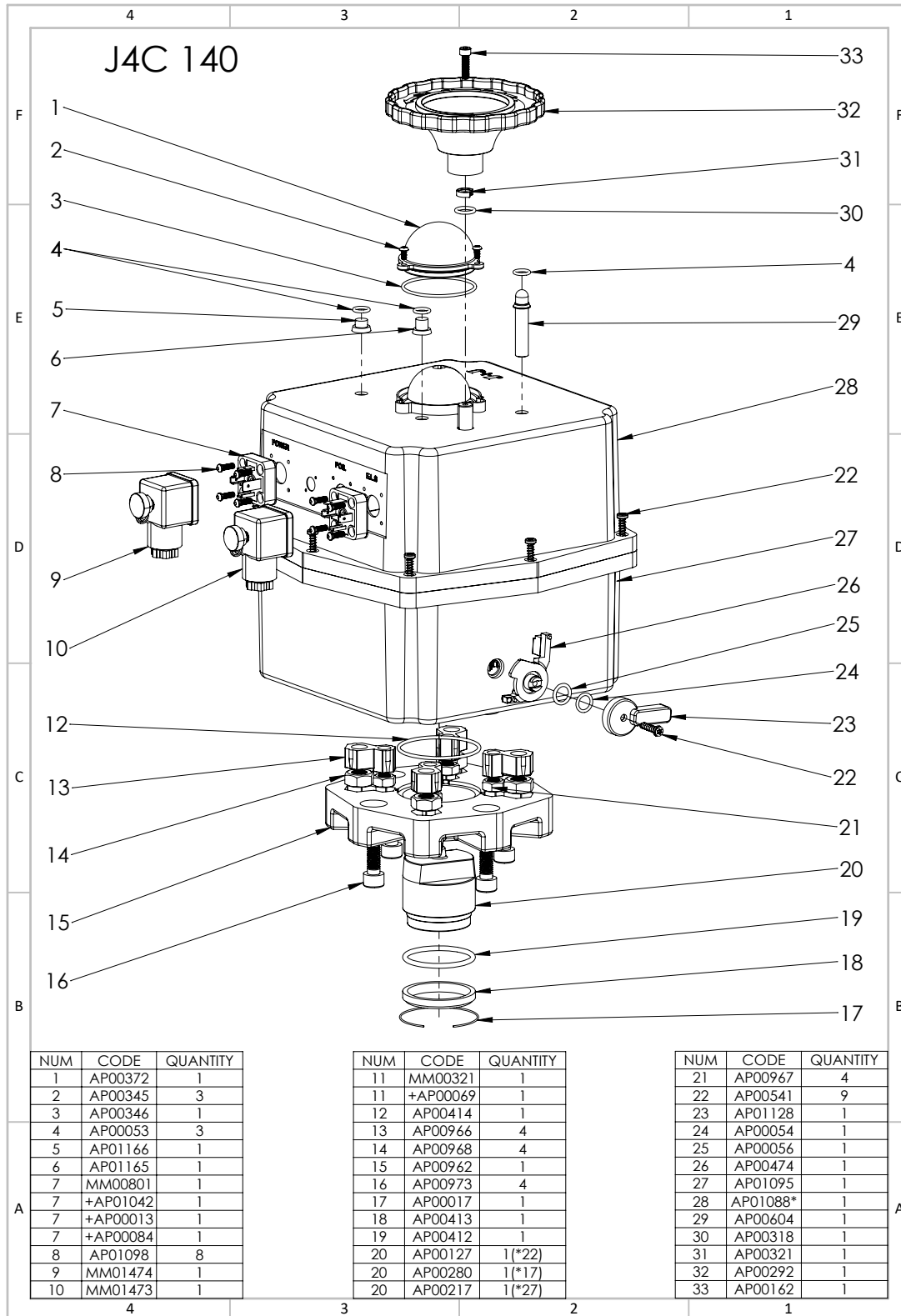

EXPLODED VIEW

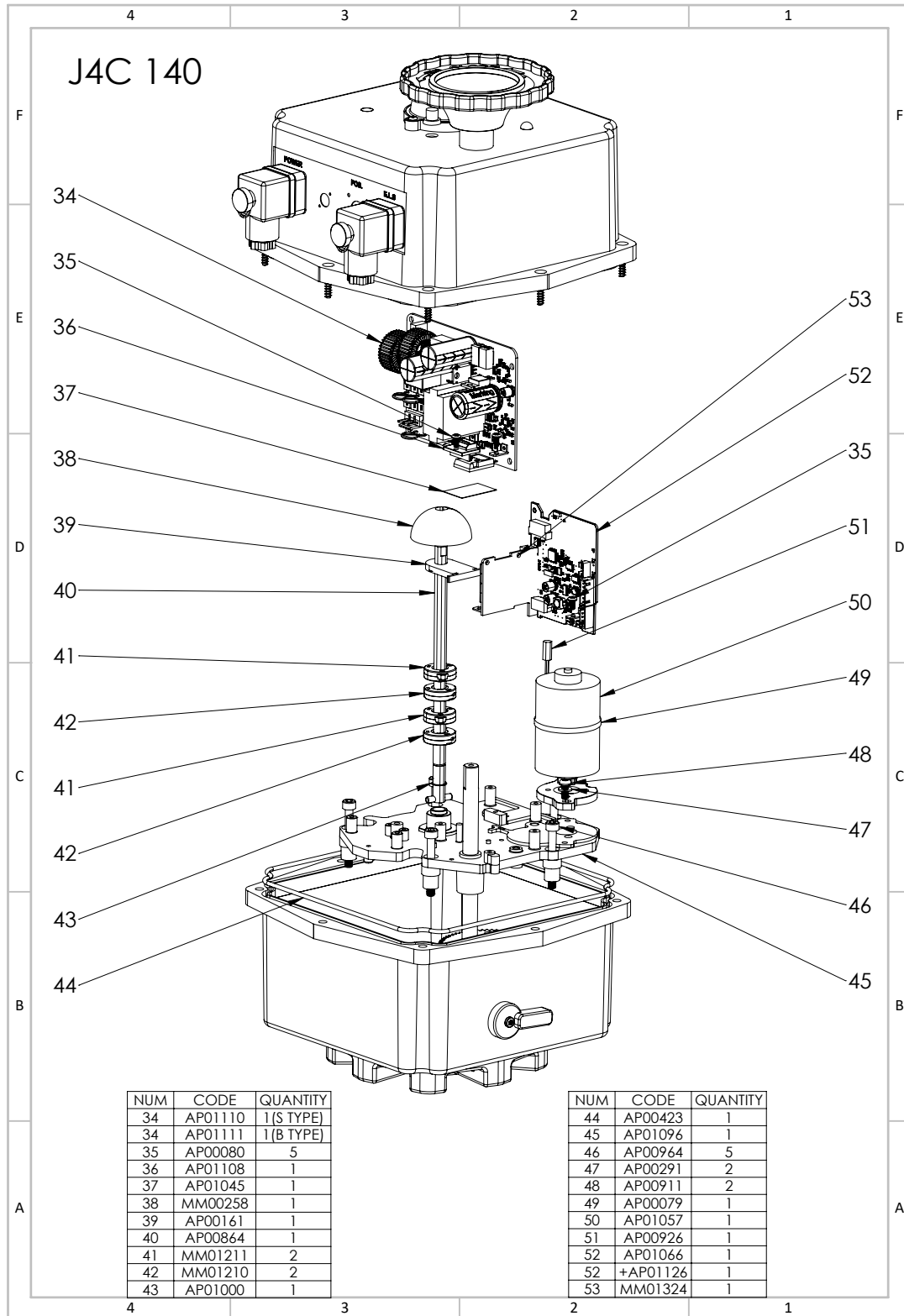

EXPLODED VIEW

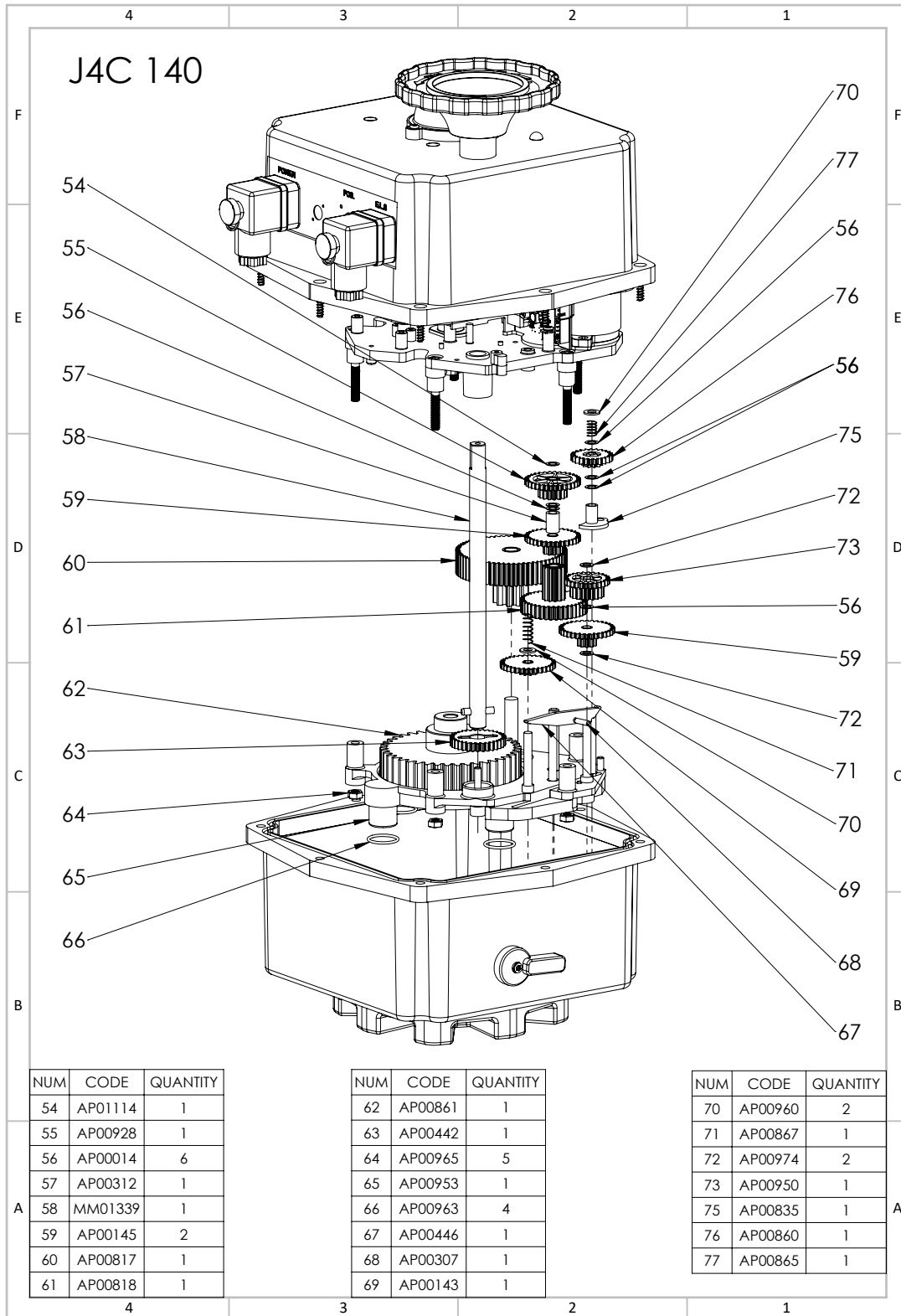

J4C 140 - CARACTERÍSTICAS GENERALES



Datos técnicos	
Tiempo maniobra sin carga	34 Sec. /90° (+/- 10%)
Par máximo arranque	170 Nm / 1504,5 lb/in
Par máximo operacional	140 Nm / 1239 lb/in
Duty rating	75%
Ángulo de maniobra	0° to 270°
Interruptores final de carrera	4 SPST NO micro (2 paros motor y 2 confirmación)
Resistencia calefactora	3,5 W
Conector grande	EN 175301-803 FORM A
Conector pequeño	DIN43650/C
Grado protección IEC 60529	IP67
Temperatura	-20°C +70°C / -4°F +158°F
Brida ISO 5211	Estándar: F07/F10 Optional: F12
Salida doble cuadrado DIN 3337	Estándar: *22 Optional: *17mm
Peso	4,72 kg

Datos electrónicos	
Limitador electrónico de par	
Motor	24VDC Brushless motor
Aislamiento	Class B
(IEC 60034) Servicio	S4
Voltaje VDC/VAC 50/60Hz -0%+5%	
S140	24-240 VDC/VAC
B140	12 VDC/VAC ONLY

Opciones	
J4C 140/300 DPS KIT posicionador digital	4-20mA, 0-20mA, 0-10V or 1-10V
J4C 140/300 BSR KIT de retorno emergencia por batería	NC - NO
Potenciómetro	1K, 5K or 10K
Actuador con 3 posiciones	0°-45°-90° or 0°-90°-180°

Materiales	Estándar	Opcional
Cuerpo	Poliamida Anticorrosiva, color Gris	Polipropileno V0, color Negro
Tapa	Poliamida Anticorrosiva, color Rojo	Polipropileno V0, color Natural
Salida	Zamak, tratamiento Cincado	Zamak, tratamiento Teflonado
Brida	Aluminio y tratamiento Cataforesis	Aluminio y tratamiento Teflonado
Ejes principales externos	Acero inoxidable	-
Tornillería exterior	Acero inoxidable	-
Engranajes	Acero y poliamida	-
Indicador visual de posición	Poliamida	-
Visor cúpula	Policarbonato	-
Levas internas ajustables	Poliamida	-

Nota: Los datos técnicos, no varían para los diferentes envoltentes

J4C 140 - MEDIDAS

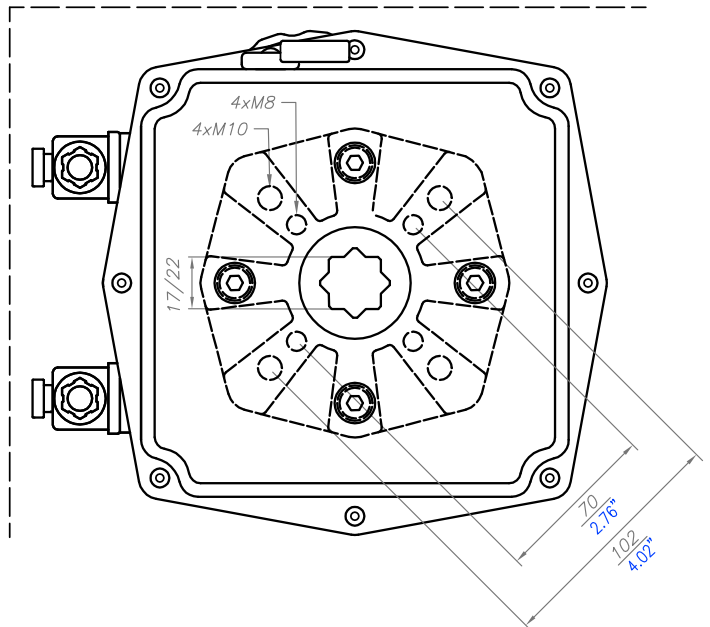
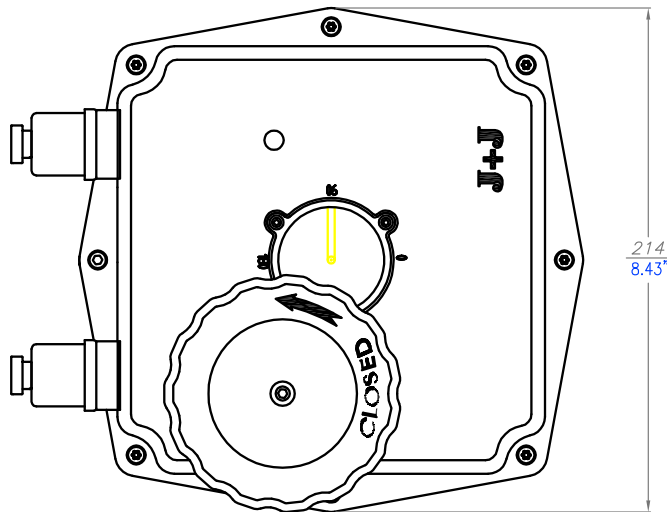
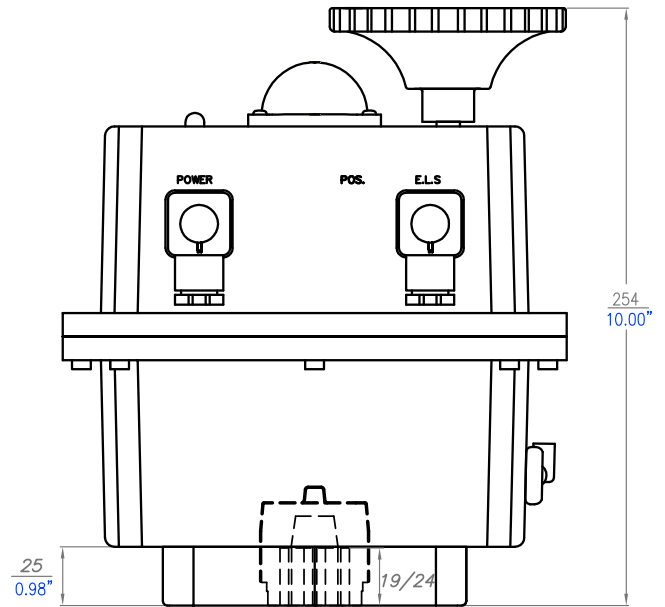
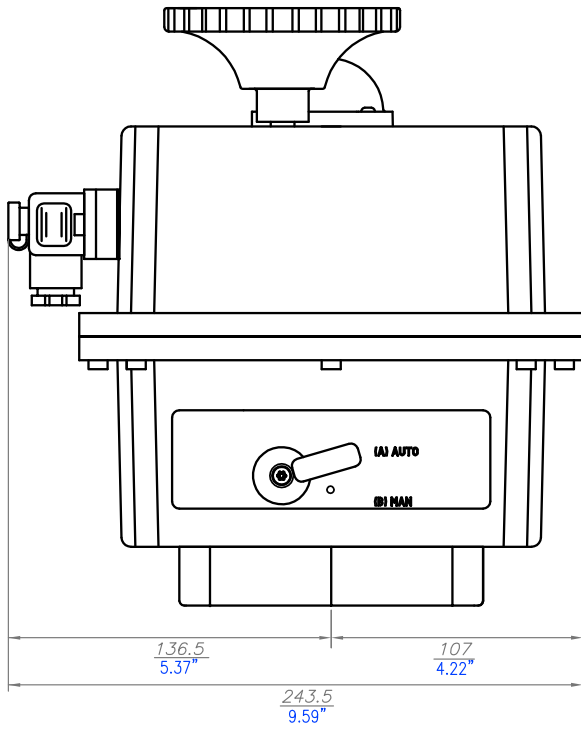

DESPIECE

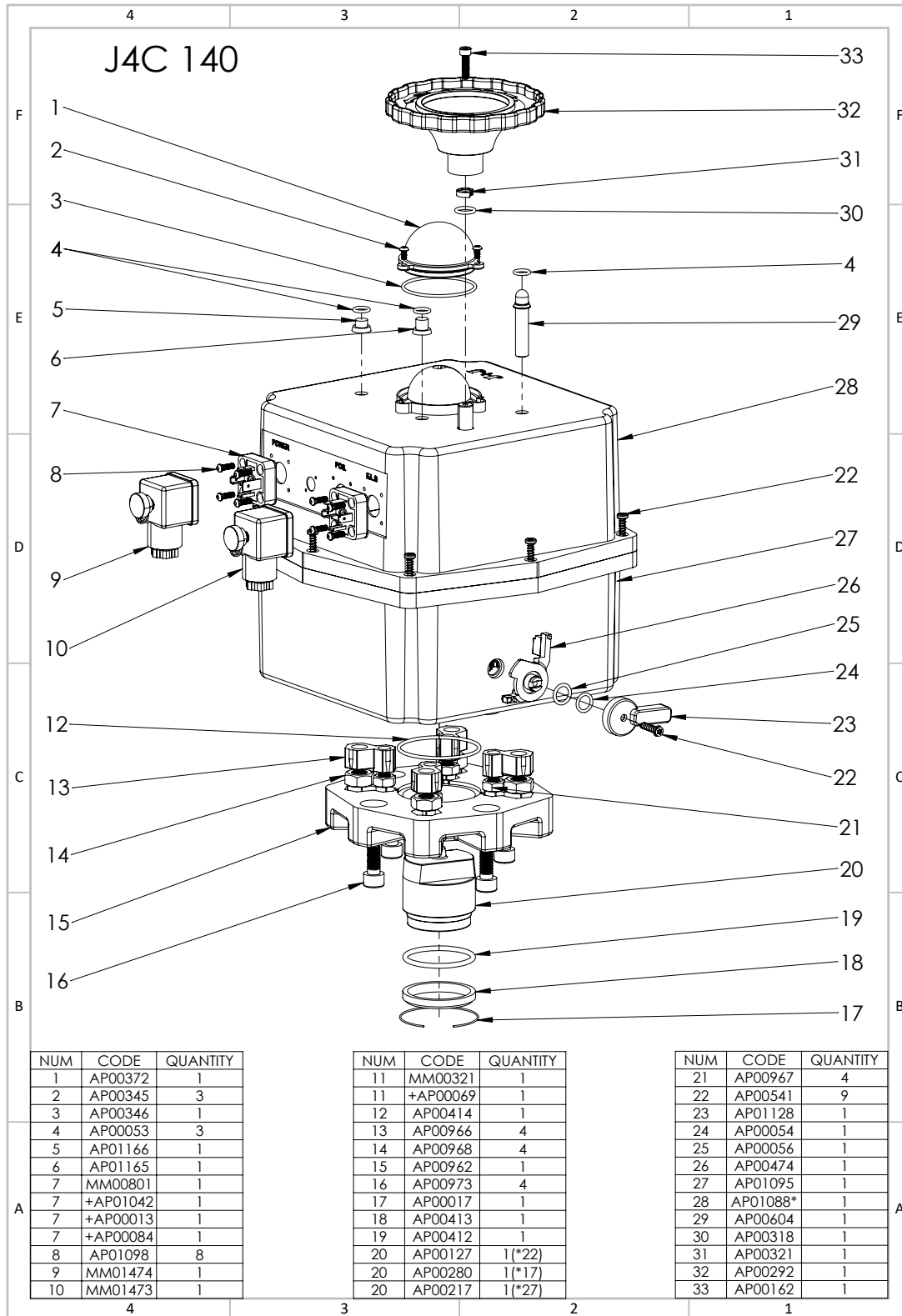

DESPIECE

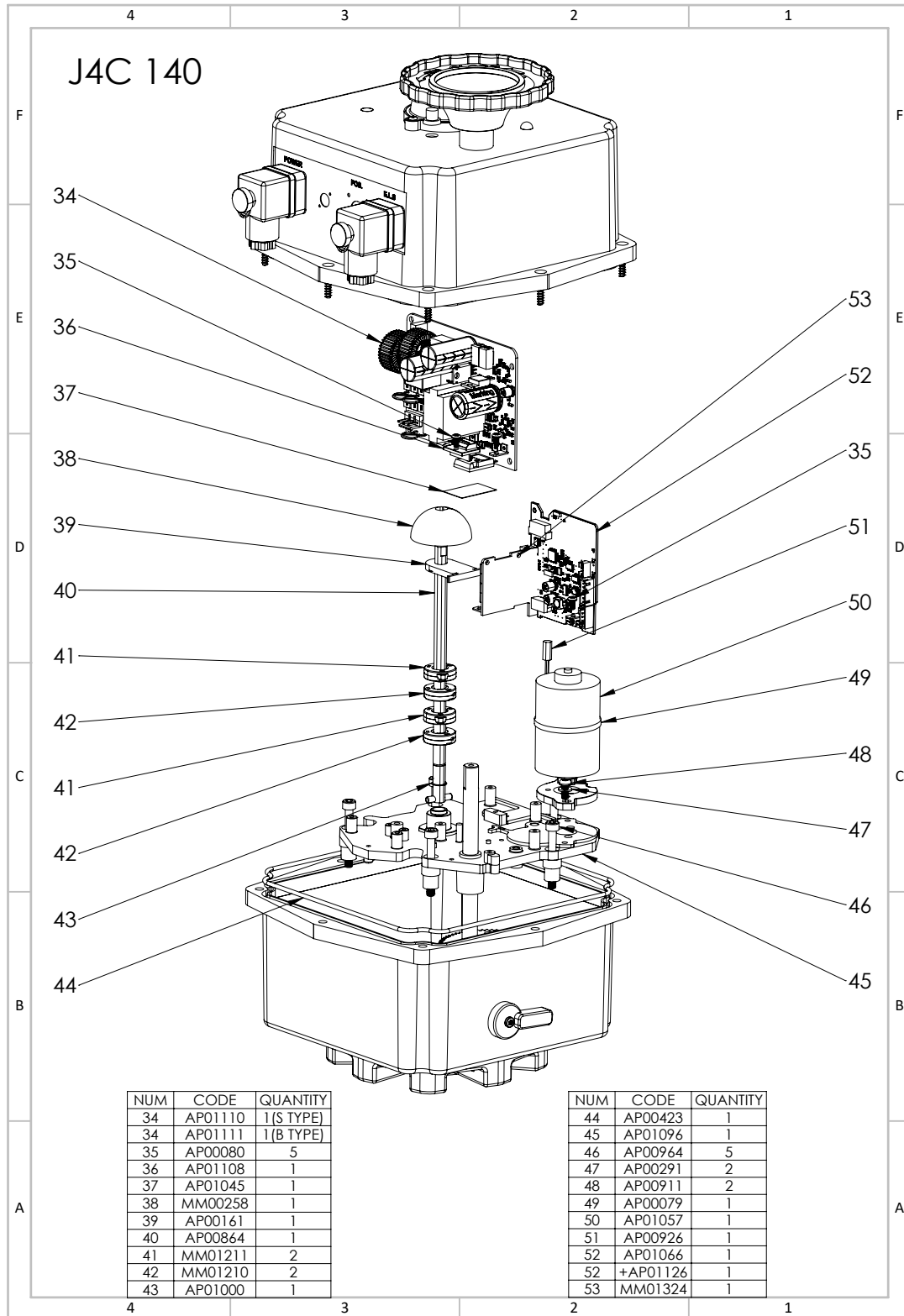

DESPIECE

