

## ELECTRICAL ACTUATORS J4M SERIES.

READ THESE INSTRUCTIONS BEFORE CONNECTING THE ACTUATOR. DAMAGE CAUSED BY NONCOMPLIANCE OF THESE INSTRUCTIONS IS NOT COVERED BY OUR WARRANTY.

J4M Electric actuators operate with the use of live electricity. It is recommended that only qualified electrical engineers be allowed to connect or adjust these actuators.

### 1. VOLTAGE

All our actuators model **S2** to **S40** are ready to work from **24 to 240 VDC / VAC 50/60Hz**.

All our actuators model **B2** to **B40** are ready to work at **12 VAC/VDC ONLY**.

### 2. ELECTRICAL CONNECTORS

**Warning:** Before connecting ensure that the voltage to be applied to the actuator is within the range shown on the identification label. The supplied electrical connectors, used to connect to the actuator are DIN plugs. Ensure the diameter of cable to be used conforms to the maximum and minimum requirements of the DIN plugs to maintain water tightness (Fig.1).

CONNECTOR	SMALL BLACK		BIG GREY or BLACK	
	DIN43650/C		EN175301-803 FORMA A	
MODEL	min Ø	máx. Ø	min Ø	máx. Ø
J4M 2 TO 40	5mm	6mm	8mm	10,5mm

(Fig.1)

**Warning:** Ensure that the square rubber seal is in place when fixing each DIN plug to the actuator. Failure to do so could allow water ingress and damage caused by this installation error will invalidate any warranty. The DIN plugs are fixed to their respective bases on the actuator housing with a screw. Do not over tight the screw when assembling (Max. 0.5Nm).

- 1. Gasket
- 2. Terminal strip
- 3. Cable fixing screws
- 4. Housing
- 5. Washer
- 6. Grommet
- 7. Gland - nut
- 8. Fixing screw
- 9. Washer
- 10. Gasket

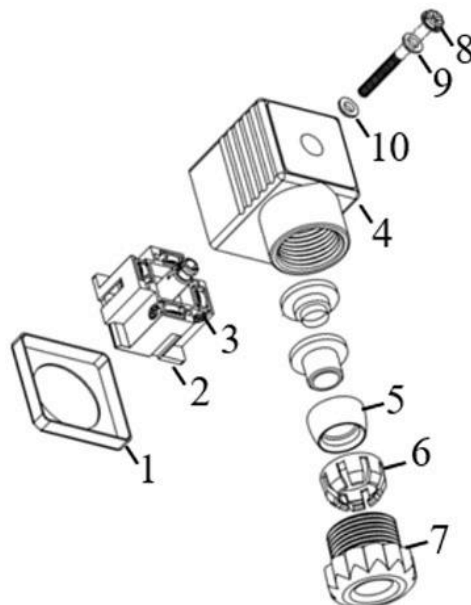

(Fig.2)

**Standard Electrical Connection, all models.**

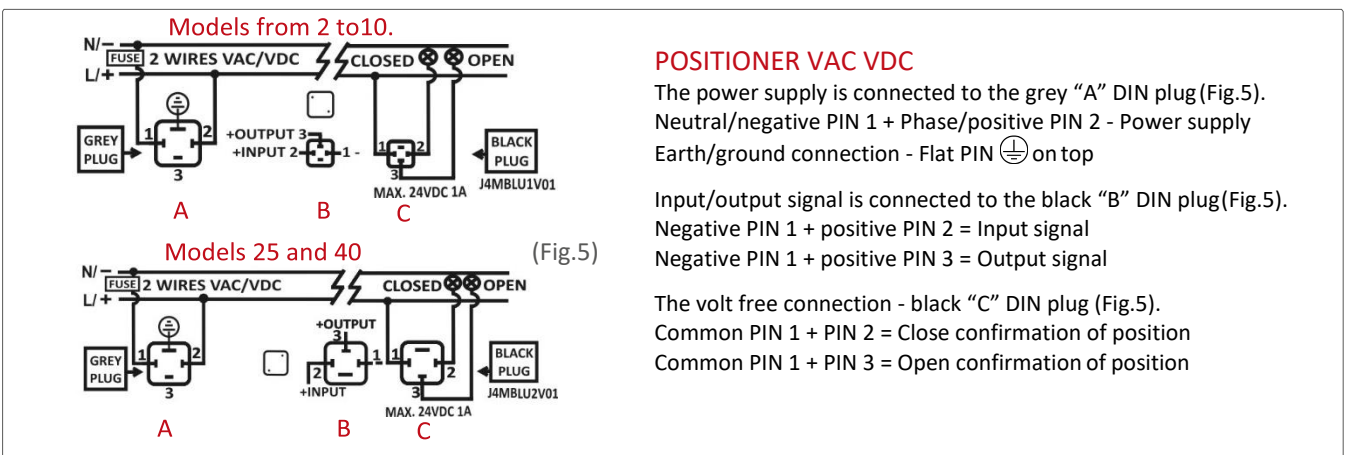
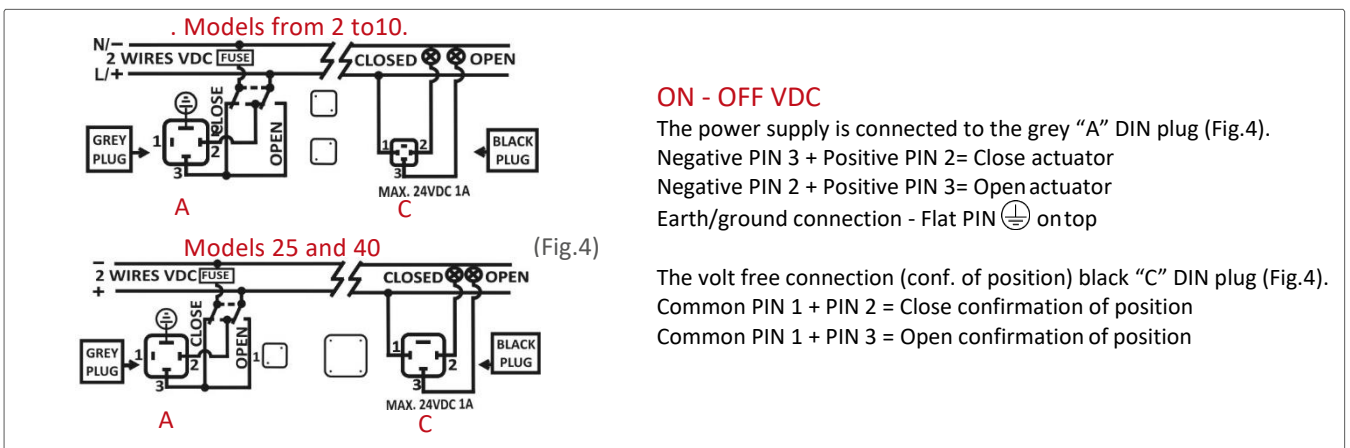
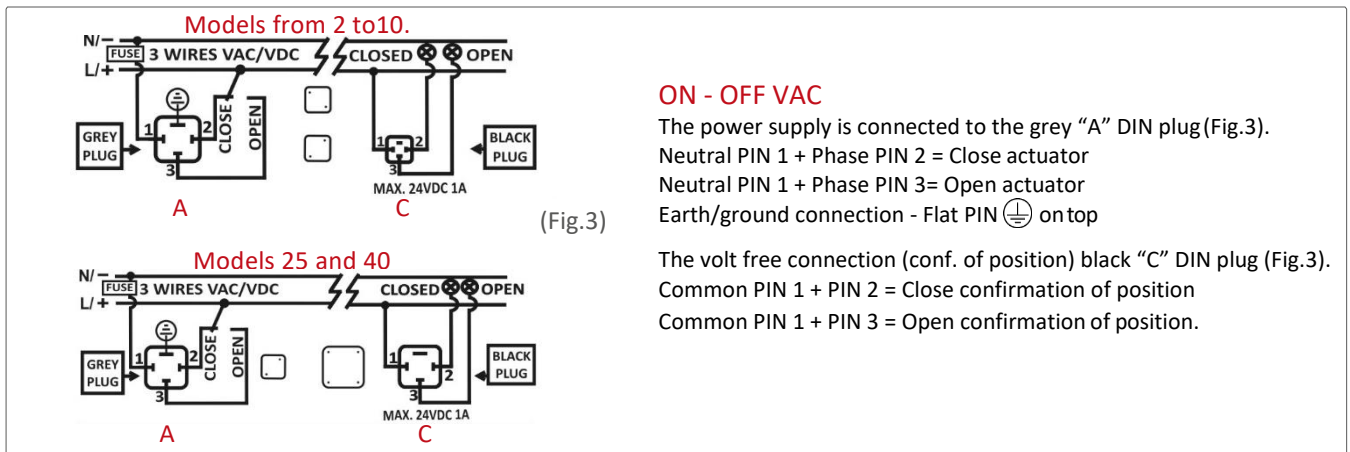

**3. VISUAL INDICATOR**

When the red indicator is not visible, means the actuator is in OPEN position. (Fig. 6.1).  
 J4M actuators could make maximum a 14-turn stroke.  
 Depending on the assembled valve turns, the red indicator could be seen more or less.  
 The image (Fig.6) is showing us an actuator in CLOSE position assembled to a 14 turn valve.



Fig. 6  
CLOSE



Fig. 6.1  
OPEN

#### 4. EMERGENCY MANUAL OVERRIDE FACILITY.

The **J4M** has 2 operating modes, automatic and manual, the required mode is selected by using a lever on the lower half of the actuator housing (Fig 7).

The 2 positions are marked:

AUTO = Automatic operation

MAN = Manual operation

**Warning:** Do not remove the selector lever securing screw, as this will allow its internal mechanism to become loose and will cause irreparable damage to the actuator's gearbox. Removing this screw will invalidate the warranty.

When "**AUTO**" position is selected:

The hand wheel, of models 2, 6, 10, 25 and 40 rotates automatically, it is very important not to block it, otherwise the actuator could suffer unreparable damages.



When "**MAN**" function is selected:

- 1-The electronic system cuts the power to the motor after a few seconds.
- 2-The mechanical connection between the motor and the output shaft is disconnected.
- 3-The desired position can be achieved by using the manual override lever or the hand wheel.
- 4-There are two ways to re-activate the motor after being isolated whilst in "MAN" position:
  - a) With the actuator in "MAN" function, turn the hand wheel to the open or close position. The motor will start working. Now change the manual override from "MAN" to "AUTO", and the actuator is ready to operate automatically again.
  - b) Change from "MAN" mode to "AUTO". Deactivate the supply voltage for a few seconds which resets the actuator and it could operate automatically again.

**ATC** is in charge of the automatic control of inner temperature. It is ON while the actuator is connected to the power supply. Therefore, we strongly recommend to maintain the power supply connected to the actuator, otherwise the ATC system would remain disconnected



## 5. EXTERNAL LED LIGHT STATUS.

The LED status light provides visual communication between the actuator and the user. The current operational status of the actuator is shown by either solid lit, or different flashing sequences of the LED light:

MULTITURN ACTUADOR OPERATIONAL STATUS	LED LIGHT STATUS
Actuator OFF	OFF
Actuator ON	OPEN=GREEN / CLOSE=RED
Actuator, running from .... to ...., (flashing LED light)	FROM OPEN TO CLOSE=RED, BLUE FROM CLOSE TO OPEN=GREEN, BLUE
Limiter function activated, running from .... to ...., (flashing LED light)	FROM OPEN TO CLOSE=RED, OFF FROM CLOSE TO OPEN=GREEN, OFF
Motor off, after fixed time.	(ORANGE, OFF) 50% FLASHING
Actuator with positioner ON.	STOP=BLUE / OPEN=BLUE, GREEN / CLOSE=BLUE, RED

## 6. DPS

If the actuator has a DPS unit (working with a 4-20mA or a 0-10V signal), needs and with a Bluetooth system, for a set-up change.

Any of the mention kits are holding their own instructions with all available configurations.

## 7. MOUNTING TO COMPONENT BEING ACTUATED

It is vital that the mounting kit used to connect the electric actuator to the component (ex: valve) is correctly manufactured and assembled. The mounting bracket's holes must be drilled to ensure that the centerline of the actuator's drive is perfectly in line with the component's drive-centerline, and that the drive coupling/ adaptor rotates around this centerline. The mounting holes of the actuator conform to ISO 5211, and the female output drive conforms to DIN 3337.

We strongly recommend that valves/components to be actuated that have ISO 5211 compliant top works are used wherever possible as it greatly assists in ensuring the concentricity of mounting the actuator to the valve.

The male square end of the drive coupling **MUST NOT** be longer than the maximum depth of the actuator female output drive when the assembly is bolted together.

Failure to comply with these instructions will cause uneven wear and dramatically reduce the working life of the valve and actuator.

In case of a power supply failure, the actuator would stop in the position it was at this moment. When the power supply is reestablished, the actuator would keep on working following the prior direction.

**VERY IMPORTANT:** Check that any object is blocking the valve (damper, etc.). Connect the actuator, following the connection diagram on the label of the actuator. We recommend that the actuator has an independent system of fuses, which could protect the actuator against other electrical devices.

If the WEEE (Waste Electrical and Electronic Equipment) contains batteries, they must be removed and deposited separately for proper management before being deposited at the collection facilities.

Batteries may contain hazardous substances that can harm the environment and human health if mishandled or disposed of improperly. Therefore, it is important to deposit them in specific containers for recycling and proper treatment. In some countries, there are selective collection programs for used batteries in supermarkets, electronic stores, or other establishments.

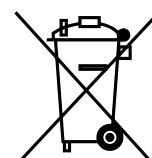

Num: RII-AEE: 8760